

JVC

SERVICE MANUAL

COLOR TELEVISION

C-N21102_{/S}
C-N21210_{/S}
AV-N21202_{/S}

BASIC CHASSIS

FV4

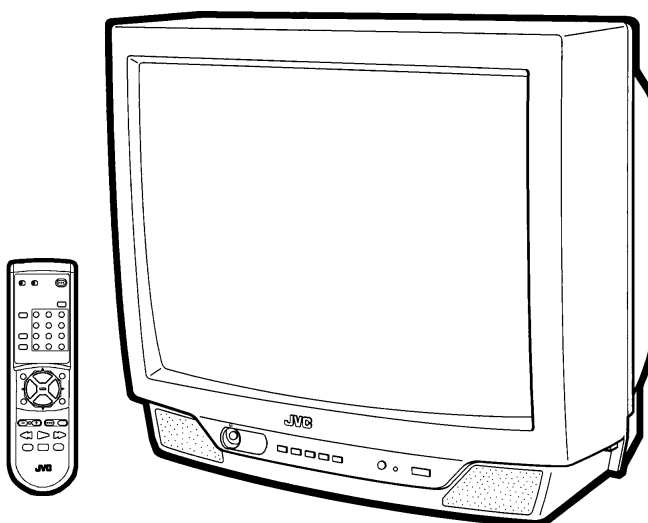

CONTENTS

■ SPECIFICATIONS	2
■ SAFETY PRECAUTIONS	3
■ FEATURES	4
■ MAIN DIFFERENCE LIST	4
■ SPECIFIC SERVICE INSTRUCTIONS	5
■ SERVICE ADJUSTMENTS	9
■ PARTS LIST	25
★ OPERATING INSTRUCTIONS	
★ STANDARD CIRCUIT DIAGRAM	2-1

SPECIFICATIONS

Items	Contents		
	C-N21102/s	C-N21210/s	AV-N21202/s
Dimensions (W × H × D)	50.3cm × 45.2cm × 49.3cm		
Mass	19.6 kg		19.9 kg
TV RF System	CCIR(M)		
Color Sound System	NTSC system		NTSC, BTSC System (Multi Channel Sound)
TV Receiving Channels and Frequency	VL Band (02~06) 54MHz~88MHz VH Band (07~13) 174MHz~216MHz UHF Band (14~69) 470MHz~806MHz		
CATV Receiving Channels and Frequency	Low Band (02~06, A-8) by (02~06&01) High Band (07~13) by (07~13) Mid Band (A~1) by (14~22) Super Band (J~W) by (23~36) Hyper Band (W+1~W+28) by (37~64) Ultra Band (W+29~W+84) by (65~125) Sub Mid Band (A8, A4~A1) by (01, 96~99) TV/CATV Total Channel 180 Channels		
Intermediate Frequency	(54MHz~804MHz)		
Video IF Carrier	45.75MHz		45.75MHz
Sound IF Carrier	41.25MHz (4.5MHz)		41.25MHz
Color Sub Carrier	3.58MHz		3.58MHz
Power Input	120V AC, 60Hz		
Power Consumption	87W		
Picture Tube	21" (51cm) Measured Diagonally		
High Voltage	26.5kV ± 1kV (at zero beam current)		
Speaker	5 × 9cm Oval type × 1		5 × 9cm Oval type × 2
Audio Power Output	1W		1W+1W
Input	Video Input 1Vp-p, 75Ω (RCA pin jack) Audio Input 500mVrms (-4dBs) ,High Impedance (RCA pin jack)		
Variable Audio Output	_____		More than 0~ 1550mVrms(+6dBs) Low impedance (400Hz when modulated 100%) (RCA pin jack)
Headphone Jack	3.5mm stereo mini jack (Sound is monaural)		3.5mm stereo mini jack (Sound is stereo)
Antenna Terminal	75(VHF/UHF) Terminal, F-Type Connector		
Remote Control Unit	RM-C205 (AA/R6/UM-3 battery × 2)		RM-C307 (AA/R6/UM-3 battery × 2)

Design & specifications are subject to change without notice.

SAFETY PRECAUTIONS

- The design of this product contains special hardware, many circuits and components specially for safety purposes. For continued protection, no changes should be made to the original design unless authorized in writing by the manufacturer. Replacement parts must be identical to those used in the original circuits. Service should be performed by qualified personnel only.
- Alterations of the design or circuitry of the products should not be made. Any design alterations or additions will void the manufacturer's warranty and will further relieve the manufacturer of responsibility for personal injury or property damage resulting therefrom.
- Many electrical and mechanical parts in the products have special safety-related characteristics. These characteristics are often not evident from visual inspection nor can the protection afforded by them necessarily be obtained by using replacement components rated for higher voltage, wattage, etc. Replacement parts which have these special safety characteristics are identified in the parts list of Service manual. **Electrical components having such features are identified by shading on the schematics and by (Δ) on the parts list in Service manual.** The use of a substitute replacement which does not have the same safety characteristics as the recommended replacement part shown in the parts list of Service manual may cause shock, fire, or other hazards.
- Use isolation transformer when hot chassis.**
The chassis and any sub-chassis contained in some products are connected to one side of the AC power line. An isolation transformer of adequate capacity should be inserted between the product and the AC power supply point while performing any service on some products when the HOT chassis is exposed.
- Don't short between the LIVE side ground and ISOLATED (NEUTRAL) side ground or EARTH side ground when repairing.**
Some model's power circuit is partly different in the GND. The difference of the GND is shown by the LIVE : (⊥) side GND, the ISOLATED(NEUTRAL) : (↵) side GND and EARTH : (⊕) side GND. Don't short between the LIVE side GND and ISOLATED(NEUTRAL) side GND or EARTH side GND and never measure with a measuring apparatus (oscilloscope etc.) the LIVE side GND and ISOLATED(NEUTRAL) side GND or EARTH side GND at the same time.
If above note will not be kept, a fuse or any parts will be broken.
- If any repair has been made to the chassis, it is recommended that the B1 setting should be checked or adjusted (See ADJUSTMENT OF B1 POWER SUPPLY).
- The high voltage applied to the picture tube must conform with that specified in Service manual. Excessive high voltage can cause an increase in X-Ray emission, arcing and possible component damage, therefore operation under excessive high voltage conditions should be kept to a minimum, or should be prevented. If severe arcing occurs, remove the AC power immediately and determine the cause by visual inspection (incorrect installation, cracked or melted high voltage harness, poor soldering, etc.). To maintain the proper minimum level of soft X-Ray emission, components in the high voltage circuitry including the picture tube must be the exact replacements or alternatives approved by the manufacturer of the complete product.
- Do not check high voltage by drawing an arc. Use a high voltage meter or a high voltage probe with a VTVM. Discharge the picture tube before attempting meter connection, by connecting a clip lead to the ground frame and connecting the other end of the lead through a 10kΩ 2W resistor to the anode button.
- When service is required, observe the original lead dress. Extra precaution should be given to assure correct lead dress in the high voltage circuit area. Where a short circuit has occurred, those components that indicate evidence of overheating should be replaced. Always use the manufacturer's replacement components.

10. Isolation Check

(Safety for Electrical Shock Hazard)

After re-assembling the product, always perform an isolation check on the exposed metal parts of the cabinet (antenna terminals, video/audio input and output terminals, Control knobs, metal cabinet, screwheads, earphone jack, control shafts, etc.) to be sure the product is safe to operate without danger of electrical shock.

(1) Dielectric Strength Test

The isolation between the AC primary circuit and all metal parts exposed to the user, particularly any exposed metal part having a return path to the chassis should withstand a voltage of 1100V AC (r.m.s.) for a period of one second.

(. . . Withstand a voltage of 1100V AC (r.m.s.) to an appliance rated up to 120V, and 3000V AC (r.m.s.) to an appliance rated 200V or more, for a period of one second.)

This method of test requires a test equipment not generally found in the service trade.

(2) Leakage Current Check

Plug the AC line cord directly into the AC outlet (do not use a line isolation transformer during this check.). Using a "Leakage Current Tester", measure the leakage current from each exposed metal part of the cabinet, particularly any exposed metal part having a return path to the chassis, to a known good earth ground (water pipe, etc.). Any leakage current must not exceed 0.5mA AC (r.m.s.).

However, in tropical area, this must not exceed 0.2mA AC (r.m.s.).

● Alternate Check Method

Plug the AC line cord directly into the AC outlet (do not use a line isolation transformer during this check.). Use an AC voltmeter having 1000 ohms per volt or more sensitivity in the following manner. Connect a 1500Ω 10W resistor paralleled by a 0.15μ F AC-type capacitor between an exposed metal part and a known good earth ground (water pipe, etc.). Measure the AC voltage across the resistor with the AC voltmeter. Move the resistor connection to each exposed metal part, particularly any exposed metal part having a return path to the chassis, and measure the AC voltage across the resistor. Now, reverse the plug in the AC outlet and repeat each measurement. Any voltage measured must not exceed 0.75V AC (r.m.s.). This corresponds to 0.5mA AC (r.m.s.). However, in tropical area, this must not exceed 0.3V AC (r.m.s.). This corresponds to 0.2mA AC (r.m.s.).

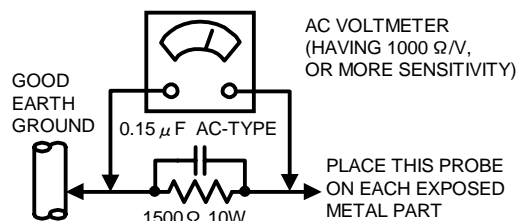

11. High voltage hold down circuit check.

After repair of the high voltage hold down circuit, this circuit shall be checked to operate correctly.

See item "How to check the high voltage hold down circuit".

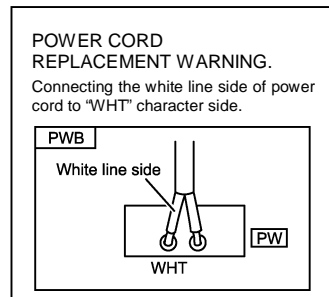
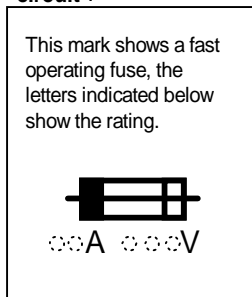

C-N21102
 C-N21210
 AV-N21202

FEATURES

- New chassis design enables use of a single board with simplified circuitry.
- Provided with miniature tuner (TV/CATV).
- Multifunctional remote control permits picture adjustment.
- Adoption of the CHANNEL GUARD function prevents the specific channels from being selected, unless the "ID number" is key in.
- I²C bus control utilizes single chip ICs.
- Adoption of the VIDEO STATUS function.
- Adoption of the ON/OFF TIMER function.
- With 75Ω V/U in common (F-Type) ANT Terminal.
- SLEEP TIMER for setting in real time.
- Closed-caption broadcasts can be viewed.
- Audio Video input terminal.
- Variable Audio output terminal. (Only for AV-N21202/s)
- Built-in MTS system. (Only for AV-N21202/s)

MAIN DIFFERENCE LIST

[Between C-N21102/s, C-N21210/s and AV-N21202/s]

△	Parts Name	Model	Monaural model	Monaural model	Stereo model
			C-N21102/s	C-N21210/s	AV-N21202/s
	MAIN PWB		SFV-1069A-M2	SFV-1068A-M2	SFV-1070A-M2
△	FRONT CABINET		GQ10020-003A-A	LC10109-018A-A	GQ10020-002A-A
△	REAR COVER		GQ10013-003A-A	LC10108-002E-A	GQ10013-002A-A
	REMOTE CONTROL UNIT		RM-C205-1C	←	RM-C307-1A
	PACKING CASE		GQ10009-017A-A	LC10181-016A-A	GQ10009-011A-A

SPECIFIC SERVICE INSTRUCTIONS

DISASSEMBLY PROCEDURE

REMOVING THE REAR COVER

1. Unplug the power supply cord.

[For C-N21102/S]

2. Remove the 9 screws marked (A) and a screw marked (B) as shown in Fig.1.

[For C-N21210/S]

2. Remove the 5 screws marked (A) and a screw marked (B) as shown in Fig.1.

[For AV-N21202/S]

2. Remove the 9 screws marked (A) and 2 screws marked (B) as shown in Fig.1.
3. Withdraw the REAR COVER toward you.

[CAUTION]

- When reinstalling the rear cover, carefully push it inward after inserting the MAIN PWB into the rear cover groove.

REMOVING THE MAIN PW BOARD

- After removing the rear cover.
1. Pick this side of the MAIN PWB and raise one slightly, take off the PWB stopper marked (C) from the cabinet bottom.
 2. Pull out the MAIN PWB as it is.
(If necessary, take off the wire clamp and connectors, etc.)

REMOVING THE SPEAKER

- After removing the MAIN PW board.

1. Remove the 2 screws marked (D).

[For C-N21102/S and C-N21210/S]

SPEAKER (× 1)

[AV-N21202/S]

SPEAKER (× 2)

CHECKING THE MAIN PW BOARD

1. To check the back side of the MAIN PW Board.
 - 1) Pull out the MAIN PWB. (Refer to REMOVING THE MAIN PWB).
 - 2) Erect the chassis vertically so that you can easily check the backside of the MAIN PW Board.

[CAUTION]

- When erecting the MAIN PWB, be careful so that there will be no contacting with other PW Board.
- Before turning on power, make sure that the CRT earth wire and other connectors are properly connected.

WIRE CLAMPING AND CABLE TYING

1. Be sure clamp the wire.
2. Never remove the cable tie used for tying the wires together.
Should it be inadvertently removed, be sure to tie the wires with a new cable tie.

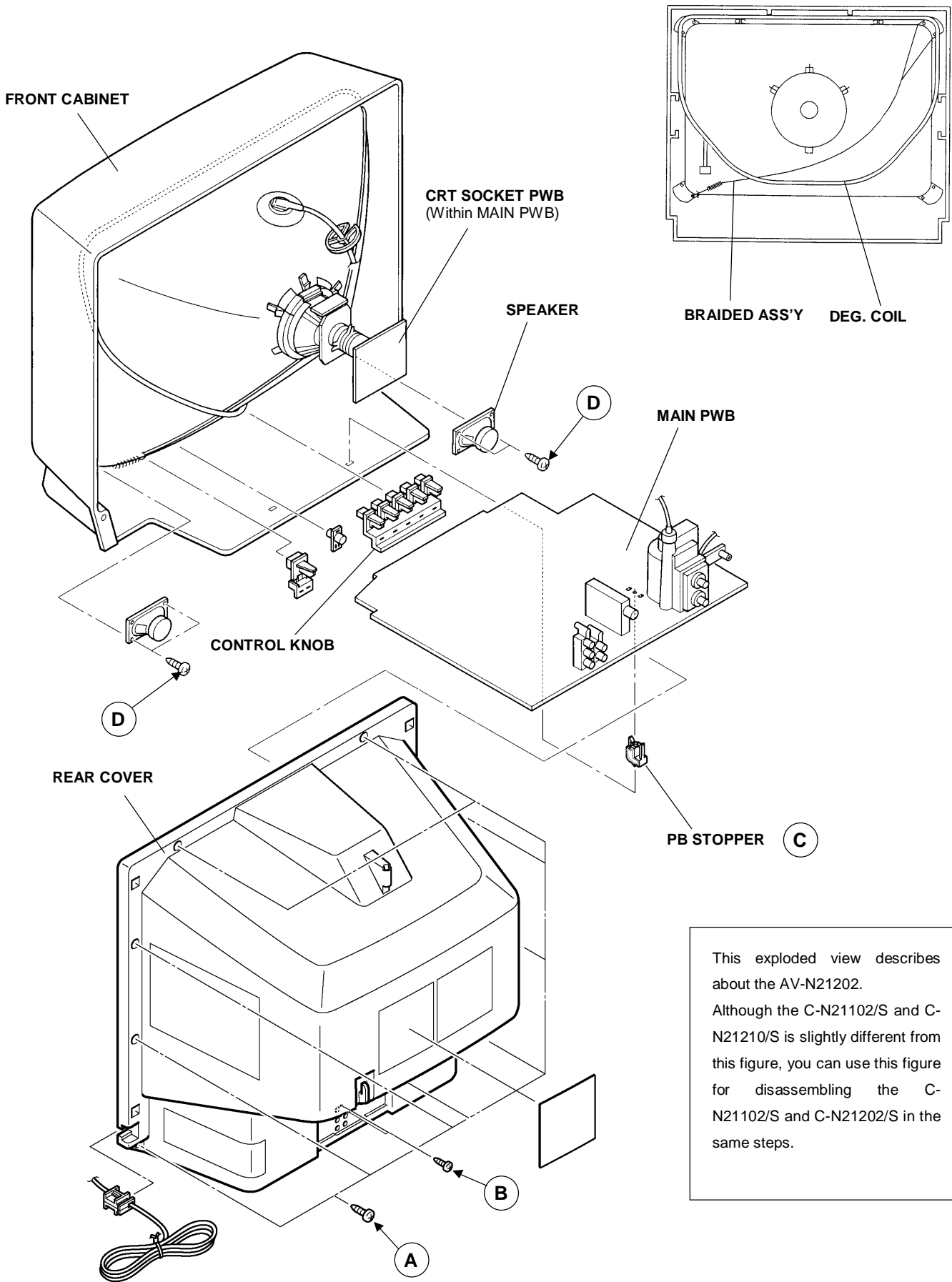

This exploded view describes about the AV-N21202. Although the C-N21102/S and C-N21210/S is slightly different from this figure, you can use this figure for disassembling the C-N21102/S and C-N21202/S in the same steps.

Fig.1

MEMORY IC REPLACEMENT

1. Memory IC

This model use a memory IC.

This memory IC stores data for proper operation of the video and deflection circuits.

When replacing, be sure to use an IC containing this (initial value) data.

2. Memory IC replacement procedure

Procedure	Screen display																						
<p>(1) Power off Switch off the power and disconnect the power cord from the outlet.</p>																							
<p>(2) Replace the memory IC Initial value must be entered into the new IC.</p>																							
<p>(3) Power on Connect the power cord to the outlet and switch on the power.</p>																							
<p>(4) System constant check and setting</p> <ol style="list-style-type: none"> 1) Press SLEEP TIMER key and, while the indication of "SLEEP 0 MIN." is being displayed, press DISPLAY key and VIDEO STATUS key on the remote control unit simultaneously. 2) The SERVICE MENU screen of Fig.1 is displayed. 3) While the SERVICE MENU is displayed, again simultaneously press the DISPLAY and VIDEO STATUS keys to display the Fig.2 SYSTEM CONSTANT screen. 4) Refer to the SYSTEM CONSTANT table and check the setting items. Where these differ, select the setting item with the MENU UP/DOWN key and adjust the setting with the MENU LEFT/RIGHT keys. (The letters of the selected item are displayed in yellow.) 5) After adjusting, release the MENU LEFT/RIGHT key to store the setting value. 6) Press the EXIT key twice to return the normal screen. 	<div data-bbox="1034 1010 1398 1279" style="border: 1px solid black; padding: 5px;"> <p style="text-align: center;">SERVICE MENU</p> <table style="width: 100%; border-collapse: collapse;"> <tr> <td style="width: 50%;">PICTURE</td> <td style="width: 50%;">SOUND ←</td> </tr> <tr> <td>GAME</td> <td></td> </tr> <tr> <td>LOW LIGHT</td> <td>HIGH LIGHT</td> </tr> <tr> <td>RF AFC CHK</td> <td></td> </tr> <tr> <td>VCO(CW)</td> <td></td> </tr> </table> <p style="font-size: small;">SELECT BY ▲▼ EXIT BY OPERATE BY ◀▶ [EXIT]</p> </div> <p style="text-align: center;">Fig.1</p> <p style="text-align: right;">[Only for AV-N21202/S]</p> <div data-bbox="1027 1487 1394 1756" style="border: 1px solid black; padding: 5px; margin-top: 20px;"> <p style="text-align: center;">SYSTEM CONSTANT</p> <table style="width: 100%; border-collapse: collapse;"> <tr> <td style="width: 30%;">MODEL</td> <td style="width: 30%;">: ***** ←</td> <td style="width: 40%;"></td> </tr> <tr> <td>V-CHIP</td> <td>: YES</td> <td></td> </tr> <tr> <td>CAN V-CHIP</td> <td>: YES</td> <td></td> </tr> <tr> <td colspan="3" style="text-align: center;">*****.*****</td> </tr> </table> <p style="font-size: small;">SELECT BY ▲▼ EXIT BY OPERATE BY ◀▶ [EXIT]</p> </div> <p style="text-align: center;">Fig.2</p> <p style="text-align: right;">Indicated Model No.</p>	PICTURE	SOUND ←	GAME		LOW LIGHT	HIGH LIGHT	RF AFC CHK		VCO(CW)		MODEL	: ***** ←		V-CHIP	: YES		CAN V-CHIP	: YES		*****.*****		
PICTURE	SOUND ←																						
GAME																							
LOW LIGHT	HIGH LIGHT																						
RF AFC CHK																							
VCO(CW)																							
MODEL	: ***** ←																						
V-CHIP	: YES																						
CAN V-CHIP	: YES																						
*****.*****																							
<p>(5) Receive channel setting Refer to the OPERATING INSTRUCTIONS(USER'S GUIDE) and set the receive channels (Channels Preset) as described.</p>																							
<p>(6) User settings Check the user setting items according to Table 2. Where these do not agree, refer to the OPERATING INSTRUCTIONS (USER'S GUIDE) and set the items as described.</p>																							
<p>(7) SERVICE MENU setting Verify what to set in the SERVICE MENU, and set whatever is necessary.(Fig.1) Refer to the SERVICE ADJUSTMENT for setting.</p>																							

TABLE 1 (System Constant setting)

Setting item	Setting content	Setting value	
		C-N21102/S C-N21210/S	AV-N21202/S
MODEL	Display the each application model	Comformable model name	
V-CHIP		YES	YES
CAN V-CHIP		YES	YES

TABLE 2 (User setting value)

Setting item	Setting value
1. Use remote controller keys POWER CHANNEL CHANNEL PRESET VOLUME INPUT (TV/VIDEO)	OFF CH 02 See OPERATING INSTRUCTIONS. 10 TV
DISPLAY SLEEP TIMER VIDEO STATUS	OFF 0 STANDARD
2. Setting of MENU TINT COLOR PICTURE BRIGHT DETAIL	CENTER CENTER CENTER CENTER CENTER
BASS TREBLE BALANCE MTS TV SPEAKER	CENTER CENTER CENTER STEREO ON [Only for AV-N21202/S]
NOISE MUTING SET VIDEO STATUS	ON ALL CENTER
SET CLOCK ON/OFF TIMER LANGUAGE CLOSED CAPTION BACKGROUND	Unnecessary to set NO SPANISH OFF BLACK
AUTO TUNER SETUP CHANNEL SUMMARY V-CHIP SET LOCK CODE	TUNER MODE : AIR Unnecessary to set OFF Unnecessary to set

SERVICE ADJUSTMENTS

ADJUSTMENT PREPARATION

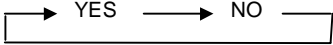
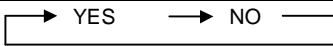
1. You can make the necessary adjustments for this unit with either the Remote Control Unit or With the adjustment tools and parts as given below.
2. Adjustment with the Remote Control Unit is made on the basis of the initial setting values, however, the new setting values which set the screen to its optimum condition may differ from the initial settings.
3. Make sure that AC power is turned on correctly.
4. Turn on the power for set and test equipment before use, and start the adjustment procedures after waiting at least 30 minutes.
5. Unless otherwise specified, prepare the most suitable reception or input signal for adjustment.

6. Never touch any adjustment parts which are not specified in the list for this adjustment - variable resistors, transformers, condensers, etc.
7. Presetting before adjustment.
Unless otherwise specified in the adjustment instructions, preset the following functions with the remote control unit:

VIDEO STATUS	STANDARD
BASS, TREBLE, BALANCE	CENTER (Only for AV-N21202/S)
TINT/COLOR PICTURE/BRIGHT DETAIL	CENTER

ADJUSTMENT EQUIPMENT

1. DC voltmeter (or digital voltmeter)
2. Oscilloscope
3. Signal generator (Pattern generator) [NTSC]
4. Remote control unit
5. TV audio multiplex signal generator.
6. Frequency counter

ADJUSTMENT ITEMS

Adjustment items	Adjustment items	Adjustment items (AV-N21202/S)
B1 POWER SUPPLY	WHITE BALANCE (Low Light)	MTS INPUT LEVEL check
IF VCO	WHITE BALANCE (High Light)	MTS STEREO VCO
RF. AGC	SUB BRIGHT	MTS SAP VCO
FOCUS	SUB CONTRAST	MTS FILTER check
V. SIZE	SUB COLOR	MTS SEPARATION
H. POSITION	SUB TINT	

ADJUSTMENT LOCATIONS

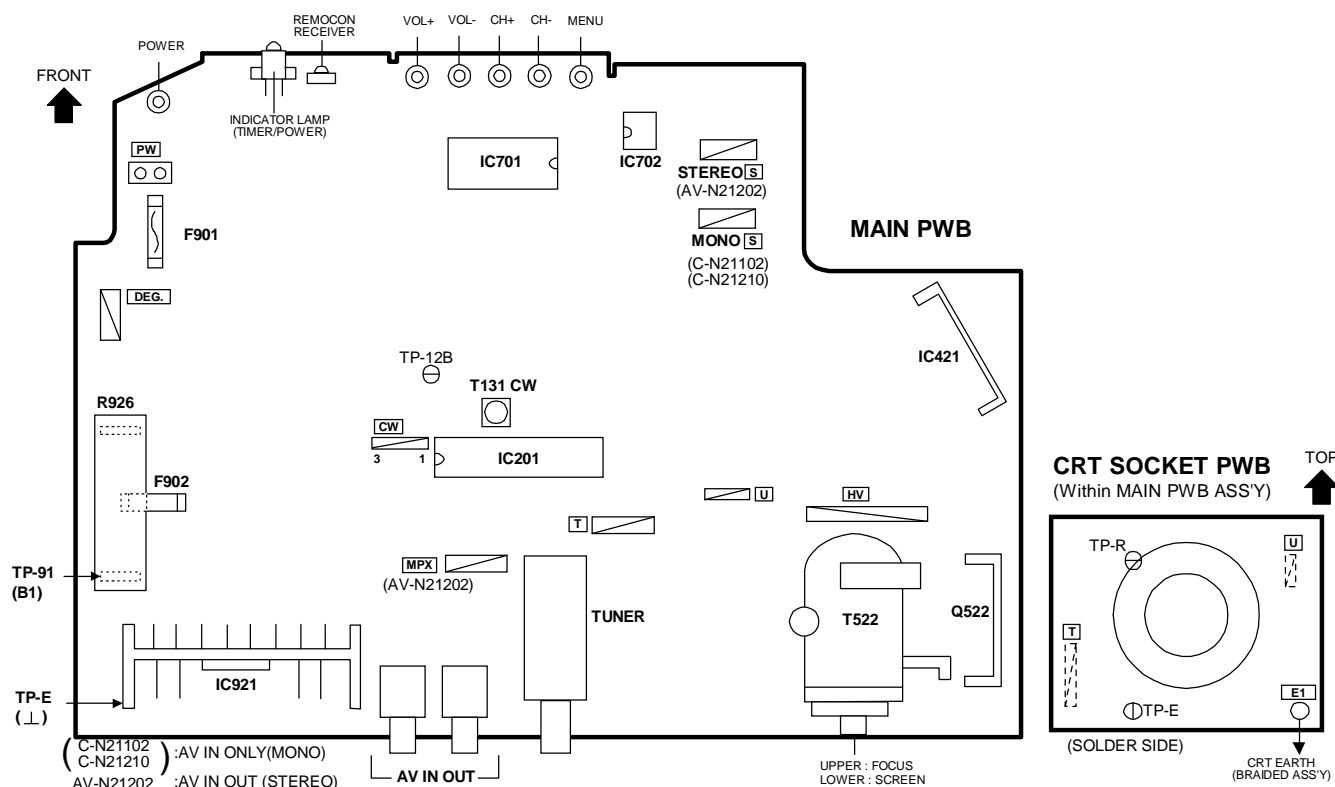

BASIC OPERATION SERVICE MENU

1. TOOL OF SERVICE MENU OPERATION

Operate the SERVICE MENU with the REMOTE CONTROL UNIT.

2. SERVICE MENU ITEMS

In general, basic setting(adjustments) items or verifications are performed in the SERVICE MENU.

- PICTURE This sets the setting values (adjustment values) of the VIDEO/CHROMA and DEFLECTION circuits.
- SOUND This sets the setting values (adjustment values) of the AUDIO circuit. **[Only for AV-N21202/S]**
- GAME This is used when the GAME MODE is adjusted.
- LOW LIGHT This sets the setting values (adjustment values) of the WHITE BALANCE circuit.
- HIGH LIGHT This sets the setting values (adjustment values) of the WHITE BALANCE circuit.
- RF AFC CHK This is used when the IF VCO is adjusted. **[Do not adjust]**
- VCO (CW) This is used when the IF VCO is adjusted.

3. Basic Operations of the SERVICE MENU

(1) How to enter the SERVICE MENU.

Press **SLEEP TIMER** key and, while the indication of "**SLEEP 0 MIN.**" is being displayed, press **DISPLAY** key and **VIDEO STATUS** key on the remote control unit simultaneously to enter the **SERVICE MENU** screen ① shown in the next figure page.

(2) SERVICE MENU screen selection

Press the UP / DOWN key of the MENU to select any of the following items.

(The letters of the selected items are displayed in yellow.)

- PICTURE
- GAME
- LOW LIGHT
- RF AFC CHK
- VCO(CW)
- SOUND[Only for AV-N21202/S]
- HIGH LIGHT

(3) Enter the any setting (adjustment) mode

● PICTURE and SOUND mode

- 1) If select any of PICTURE or SOUND items, and the LEFT / RIGHT key is pressed from SERVICE MENU (MAIN MENU), the screen ② will be displayed as shown in figure page later.
- 2) Then the UP / DOWN key is pressed, the PICTURE mode screen ③ or the SOUND mode screen ④ is displayed, and the PICTURE or SOUND setting can be performed.

● GAME, LOW LIGHT, HIGH LIGHT, RF AFC CHK and VCO (CW) mode

- 1) If select any of GAME / LOW LIGHT / HIGH LIGHT / RF AFC CHK / VCO (CW) items, and the LEFT / RIGHT key is pressed from SERVICE MENU (MAIN MENU), the screens ⑤ ⑥ ⑦ ⑧ ⑨ will be displayed as shown in figure page later.
- 2) Then the settings or verifications can be performed.

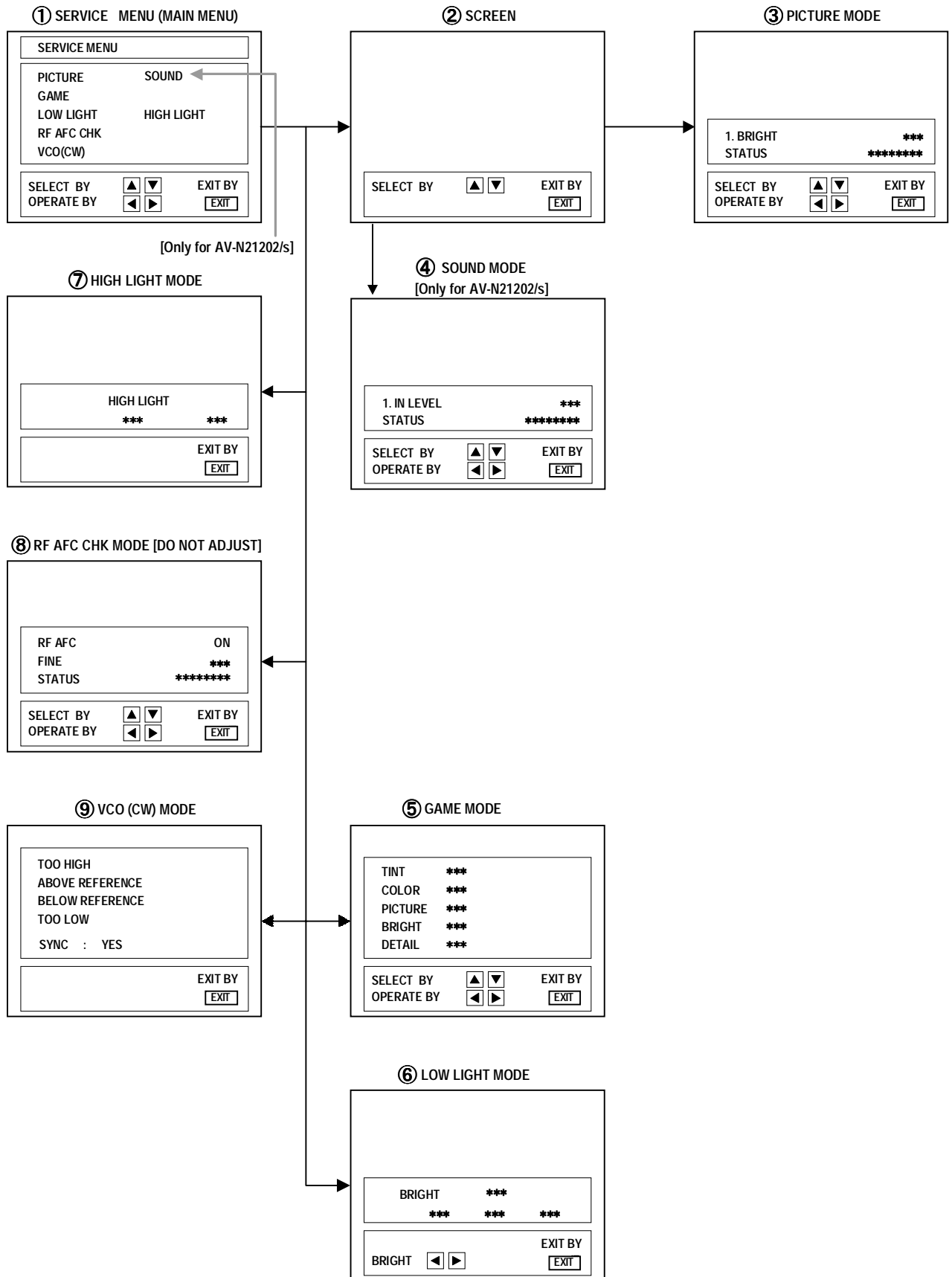

(4) Setting method

- 1) UP / DOWN key of the MENU
 Select the SETTING ITEM.
- 2) LEFT / RIGHT key of the MENU
 Setting(adjust) the SETTING VALUE of the SETTING ITEM.
 When the key is released the SETTING VALUE will be stored (memorized).
- 3) EXIT key
 Returns to the previous screen.

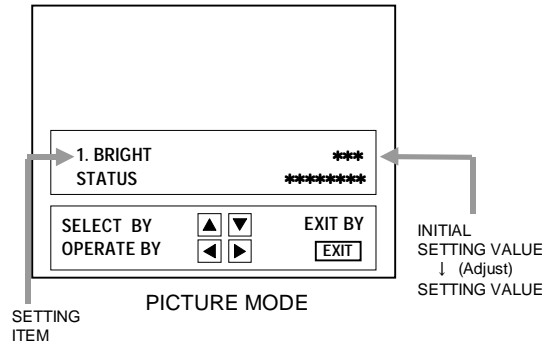

(5) Releasing SERVICE MENU

- 1) After returning to the SERVICE MENU upon completion of the setting (adjustment) work, press the EXIT key again.

- ★ The settings for LOW LIGHT and HIGH LIGHT are described in the WHITE BALANCE page of ADJUSTMENT.
- ★ The setting for VCO(CW) are described in the IF VCO page of ADJUSTMENT.

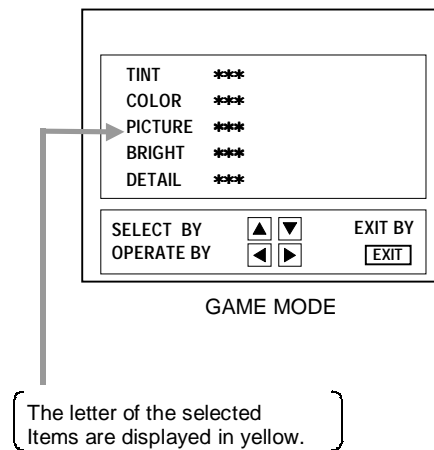
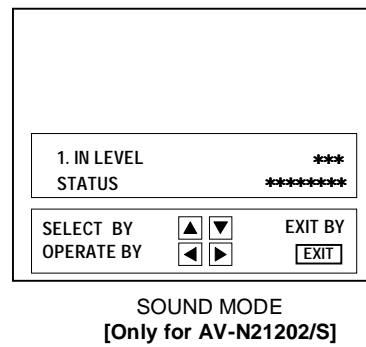

INITIAL SETTING VALUE OF SERVICE MENU

- Adjustment of the SERVICE MENU is made on the basis of the initial setting values; however, the new setting values which set the screen in its optimum condition may differ from the initial setting.
- Do not change the initial setting values of the setting (Adjustment) items not listed in "ADJUSTMENT".

● PICTURE MODE

- The four setting items in the video mode No.7 EXT BRI., No.8 EXT PIC., No.11 EXT TINT and No.12 EXT COL. are linked to the items in the TV MODE No.1 BRIGHT, No.2 PICTURE, No.5 TINT and No.6 COLOR, respectively. When the setting items in the TV mode are adjusted, the values in the setting items in the video mode are revised automatically to the same values in the TV mode.(The initial setting values given in () are off-set values.)
- When the four items (No.7, 8, 11 and 12) are adjusted in the video mode, the setting values in each item are revised independently.

No.	Setting (Adjustment) items	Variable range	initial setting value	
			C-N21102/s C-N21210/S	AV-N21202/S
1.	BRIGHT	0 ~ 127	64	64
2.	PICTURE	0 ~ 127	95	95
3.	TV DTL(TV DETAIL)	0 ~ 63	26	26
4.	TV BPF(TV B.P.FILTER)	0 / 1	0	0
5.	TINT	0 ~ 127	70	70
6.	COLOR	0 ~ 127	48	48
7.	EXT BRI.(EXT.BRIGHT)	±25	(-1)	(±0)
8.	EXT PIC.(EXT.PICTURE)	±25	(±0)	(±0)
9.	EXT DTL(EXT.DETAIL)	0 ~ 63	26	26
10.	EXT BPF(EXT.B.P.FILTER)	0 / 1	0	0
11.	EXT TINT	±25	(±0)	(+1)
12.	EXT COL.(EXT.COLOR)	±25	(±0)	(+3)
13.	V SIZE	0 ~ 63	38	38
14.	V CENT.(V.CENTER)	0 ~ 7	0	0
15.	H POS.(H.POSITION)	0 ~ 31	20	20
16.	OSD HP (OSD H POSITION)	0 ~ 31	26	26
17.	OSD VP (OSD V POSITION)	0 ~ 15	14	14
18.	H. AFC	0 / 1	0	0
19.	RF AGC	0 ~ 63	40	40
20.	OSC SEL.	0/1	—	0

● SOUND MODE [Only for AV-N21202/S]

No.	Setting (Adjustment) item	Variable range	Initial setting value
1.	IN LEVEL (INPUT LEVEL)	0~63	29
2.	FH MON. (FM MONITOR)	0 / 1	0
3.	ST VCO (STEREO VCO)	0~63	20
4.	PILOT (PILOT CANCELER)	0 / 1	0
5.	FILTER	0~63	25
6.	LOW SEP. (LOW SEPARATION)	0~63	32
7.	HI SEP. (HI SEPARATION)	0~63	16
8.	5FH MON. (5FH MONITOR)	0 / 1	0
9.	SAP VCO	0~63	14
10.	FIL. OFF.	±10	0

● GAME MODE

Setting (Adjustment) item	Variable range	Initial setting value
TINT	±20	±0
COLOR	±20	±0
PICTURE	±20	-10
BRIGHT	±20	-5
DETAIL	±15	+5

● LOW LIGHT MODE

Setting (Adjustment) item	Variable range	initial setting value
R CUTOFF	0 ~ 255	20
G CUTOFF	0 ~ 255	20
B CUTOFF	0 ~ 255	20

● HIGH LIGHT MODE

Setting (Adjustment) item	Variable range	initial setting value
G DRIVE	0 ~ 255	128
B DRIVE	0 ~ 255	128

● RF AFC CHK MODE

Setting (Adjustment) item	Variable range	initial setting value
RF AFC	ON / OFF	ON
FINE	-77 ~ +77	± × × (DO NOT ADJUST)

■ ADJUSTMENTS

B1 POWER SUPPLY

Item	Measuring instrument	Test point	Adjustment part	Description
Check of B1 POWER SUPPLY	DC Voltmeter	TP-91 (B1) TP-E(L)		<ol style="list-style-type: none"> 1. Receive a black-and-white signal. 2. Connect the DC Voltmeter to TP-91 (B1) and TP-E(L). 3. Confirm that the voltage is DC134V^{+2V}_{-2.5V}.

ADJUSTMENT OF VIDEO / DEF. CIRCUIT

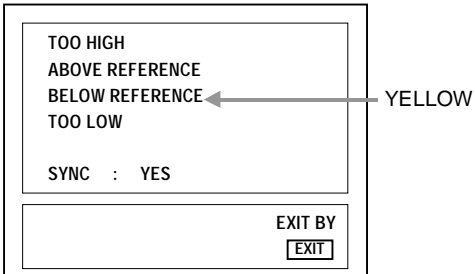
Item	Measuring instrument	Test point	Adjustment part	Description
IF VCO adjustment	Signal generator		CW TRANSF. (T131) [VCO(CW)] MODE	<p>Under normal conditions, no adjustment is required.</p> <ol style="list-style-type: none"> 1. Receive a NTSC broadcast. (use channels without offset frequency). 2. Select the VCO(CW) mode from the SERVICE MENU. 3. Confirm the color change (yellow) from "TOO HIGH" to "TOO LOW" by CW TRANSF. and "SYNC : YES" being shown on the screen. Then, adjust CW TRANSF. until "BELOW REFERENCE" mark turns yellow and confirm again "SYNC : YES" being shown on the screen.
				
RF. AGC adjustment			No.19 RF AGC	<ol style="list-style-type: none"> 1. Receive a broadcast. 2. Select "No.19 RF AGC" of the PICTURE MODE. 3. Press the MUTE key and turn off color. 4. With the MENU LEFT key, get noise in the screen picture. (0 side of setting value) 5. Press the MENU RIGHT key and stop when noise disappears from the screen. 6. Change to other channels and make sure that there is no irregularity. 7. Press the MUTE key and get color out.
FOCUS adjustment	Signal generator		FOCUS VR [In HVT]	<ol style="list-style-type: none"> 1. Receive a crosshatch signal. 2. While looking at the screen, adjust FOCUS VR so that the vertical and horizontal lines will be clear and in fine detail. 3. Make sure that the picture is in focus even when the screen gets darkened.

Item	Measuring instruments	Test point	Adjustment part	Description
V.SIZE Adjustment	Signal generator		No.13 V.SIZE	<ol style="list-style-type: none"> 1. Receive a crosshatch signal. 2. Select No.13 V SIZE in the PICTURE MODE. 3. Set the initial setting value of No.13 V SIZE with the LEFT / RIGHT key of the MENU. 4. Adjust No.13 V SIZE until the vertical screen size is 92%.
H.POSITION Adjustment	Signal generator		No.15 H POS.	<ol style="list-style-type: none"> 1. Receive a crosshatch signal. 2. Select the No.15 H POS. of the PICTURE MODE. 3. Set the initial setting value of the No.15 H POS. with the LEFT / RIGHT key of the MENU. 4. Adjust the No.15 H POS. until the screen will be horizontally centered.

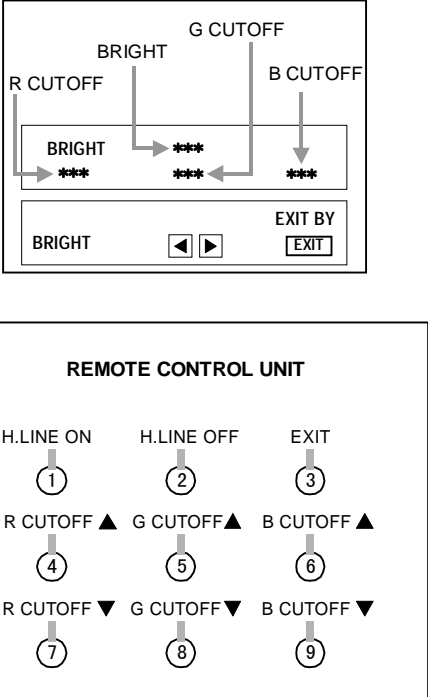
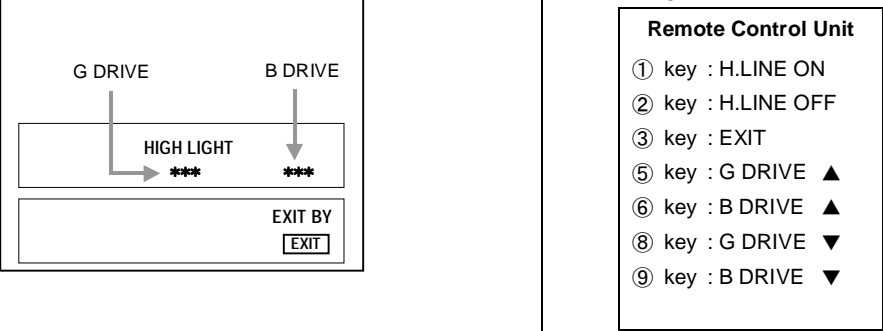
Item	Measuring instruments	Test point	Adjustment part	Description
<p>WHITE BALANCE (Low Light) Adjustment</p>	<p>Signal generator</p>		<p>BRIGHT</p> <p>R. CUTOFF G. CUTOFF B. CUTOFF</p> <p>SCREEN VR [In HVT]</p>	<ol style="list-style-type: none"> 1. Receive a black-and-white signal.(Color off) 2. Select the [LOW LIGHT] MODE from the SERVICE MENU. 3. Set the initial setting value of BRIGHT with the LEFT / RIGHT key of the remote control unit. 4. Set the initial setting value of R CUTOFF, G CUTOFF and B CUTOFF with the ④ to ⑨ key of the remote control unit. 5. Display a single horizontal line by pressing the ① key of the remote control unit. 6. Turn the screen VR all the way to the left. 7. Turn the screen VR gradually to the right from the left until either one of the red, blue or green colors appears faintly. 8. Adjust the two colors which did not appear until the single horizontal line that is displayed becomes white using the ④ to ⑨ keys of the remote control unit. 9. Turn the screen VR to where the single horizontal line glows faintly. 10. Press the ② key to return to the regular screen. <ul style="list-style-type: none"> • The ③ EXIT key is the cancel key for the WHITE BALANCE.
<p>[LOW LIGHT] MODE</p> 				
<p>WHITE BALANCE (High Light) Adjustment</p>	<p>Signal generator</p>		<p>G. DRIVE B. DRIVE</p>	<ol style="list-style-type: none"> 1. Receive a black-and-white signal. (Color off) 2. Select the [HIGH LIGHT] MODE in the SERVICE MENU. 3. Set the initial setting value of G DRIVE and B DRIVE with the ⑤, ⑥, ⑧ and ⑨ keys of the remote control unit. 4. Adjust the screen until it becomes white using the ⑤, ⑥, ⑧ and ⑨ keys of the remote control unit. <p>* The ③ (EXIT) key is the cancel key for the WHITE BALANCE.</p> <div style="border: 1px solid black; padding: 5px; margin-top: 10px;"> <p style="text-align: center;">Remote Control Unit</p> <p>① key : H.LINE ON ② key : H.LINE OFF ③ key : EXIT ⑤ key : G DRIVE ▲ ⑥ key : B DRIVE ▲ ⑧ key : G DRIVE ▼ ⑨ key : B DRIVE ▼</p> </div>
<p>[HIGH LIGHT] MODE</p> 				

Item	Measuring instruments	Test point	Adjustment part	Description
SUB BRIGHT Adjustment			No.1 BRIGHT	<ol style="list-style-type: none"> 1. Receive a broadcast. 2. Select No.1 BRIGHT of the PICTURE MODE. 3. Set the initial setting value of the No.1 BRIGHT with the LEFT / RIGHT key of the MENU. 4. If the brightness is not best with the initial setting value, make fine adjustment of the No.1 BRIGHT until you get the optimum brightness.
SUB CONTRAST Adjustment			No.2 PICTURE	<ol style="list-style-type: none"> 1. Receive a broadcast. 2. Select No.2 PICTURE of the PICTURE MODE. 3. Set the initial setting value of the No.2 PICTURE with the LEFT / RIGHT key of the MENU. 4. If the contrast is not best with the initial setting value, make fine adjustment of the No.2 PICTURE until you get the optimum contrast.
SUB COLOR Adjustment			No.6 COLOR	<ol style="list-style-type: none"> 1. Receive a broadcast. 2. Select No.6 COLOR of the PICTURE MODE. 3. Set the initial setting value of the No.6 COLOR with the LEFT / RIGHT key of the MENU. 4. If the color is not best with the initial setting value, make fine adjustment of the No.6 COLOR until you get the optimum color.
SUB TINT Adjustment			No.5 TINT	<ol style="list-style-type: none"> 1. Receive a broadcast. 2. Select No.5 TINT of the PICTURE MODE. 3. Set the initial setting value of the No.5 TINT with the LEFT / RIGHT key of the MENU. 4. If the tint is not best with the initial setting value, make fine adjustment of the No.5 TINT until you get the optimum tint.

ADJUSTMENT OF MTS CIRCUIT [Only for AV-N21202/S]

Item	Measuring instrument	Test point	Adjustment part	Description
MTS INPUT LEVEL check			No.1 IN LEVEL	<ol style="list-style-type: none"> 1. Select the "No.1 IN LEVEL" of the SOUND MODE. 2. Verify that the "No.1 IN LEVEL" is set at its initial setting value.
MTS STEREO VCO adjustment	<p>Signal generator</p> <p>Frequency counter</p>	R OUT [AUDIO OUT]	<p>No.2 FH MON.</p> <p>No.3 ST VCO</p>	<ol style="list-style-type: none"> 1. Receive a RF signal (non-modulated sound signal) from the antenna terminal. 2. Select the "No.2 FH MON." of SOUND MODE, and change the setting value from 0 to 1. 3. Connect the Frequency Counter to R OUT RCA pin of the AUDIO OUT. 4. Select the "No.3 ST VCO". 5. Set the initial setting value of the "No.3 ST VCO" with the LEFT/RIGHT key of the menu. 6. Adjust the "No.3 ST VCO" so that the Frequency Counter will display $15.73\text{kHz} \pm 0.1\text{kHz}$. 7. Select the "No.2 FH MON." of the SOUND MODE, and reset the setting value from 1 to 0.

Item	Measuring instrument	Test point	Adjustment part	Description
MTS SAP VCO adjustment	Signal generator Frequency counter	【MPX】 Connector 【4】 pin SDA 【3】 pin GND R OUT [AUDIO OUT]	No.8 5FH MON. No.9 SAP VCO	<ol style="list-style-type: none"> 1. Receive a RF signal (non modulated sound signal) from the antenna terminal. 2. Connect between pin 【4】 of 【MPX】 connector and GND (Pin 【3】 of 【MPX】 connector) through 1MΩ Resistor. 3. Select the “No.8 5FH MON.” of the SOUND MODE, and reset the setting value from 0 to 1. 4. Connect the Frequency Counter to R OUT RCA pin of the AUDIO OUT. 5. Select the “No.9 SAP VCO”. 6. Set the initial setting value of “No.9 SAP VCO” with the LEFT/RIGHT key of the menu. 7. Adjust the “No.9 SAP VCO” so that the Frequency Counter will display 78.67kHz\pm0.5kHz. 8. Select the “No.8 5FH MON.” of the SOUND MODE, and reset the setting value from 1 to 0.
MTS FILTER check			No.5 FILTER	<ol style="list-style-type: none"> 1. Select the “No.5 FILTER” of the SOUND MODE. 2. Verify that the “No.5 FILTER” is set at its initial setting value.
MTS SEPARATION adjustment	TV audio multiplex signal generator Oscilloscope	L OUT R OUT [AUDIO OUT]	No.6 LOW SEP. No.7 HI SEP.	<ol style="list-style-type: none"> 1. Input a stereo L signal (300Hz) from the TV audio multiplex signal generator to the antenna terminal. 2. Connect an oscilloscope to L OUT RCA pin of the AUDIO OUT, and display one cycle portion of the 300Hz signal. 3. Change the connection of the oscilloscope to R OUT RCA pin of the AUDIO OUT, and enlarge the voltage axis. 4. Select the “No.6 LOW SEP.” of the SOUND MODE. 5. Set the initial setting value of the “No.6 LOW SEP.” with the LEFT/RIGHT key of the menu. 6. Adjust the “No.6 LOW SEP.” so that the stroke element of the 300Hz signal will become minimum. 7. Change the signal to 3kHz, and similarly adjust the “No.7 HI SEP.”.

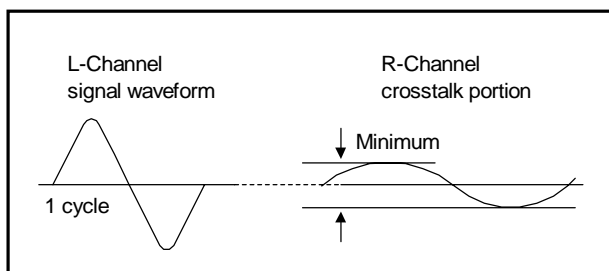

PURITY, CONVERGENCE

PURITY ADJUSTMENT

1. Demagnetize CRT with the demagnetizer.
2. Loosen the retainer screw of the deflection yoke.
3. Remove the wedges.
4. Input a green raster signal from the signal generator, and turn the screen to green raster.
5. Move the deflection yoke backward.
6. Bring the long lug of the purity magnets on the short lug and position them horizontally. (Fig.2)
7. Adjust the gap between two lugs so that the GREEN RASTER will come into the center of the screen. (Fig.3)
8. Move the deflection yoke forward, and fix the position of the deflection yoke so that the whole screen will become green.
9. Insert the wedge to the top side of the deflection yoke so that it will not move.
10. Input a crosshatch signal.
11. Verify that the screen is horizontal.
12. Input red and blue raster signals, and make sure that purity is properly adjusted.

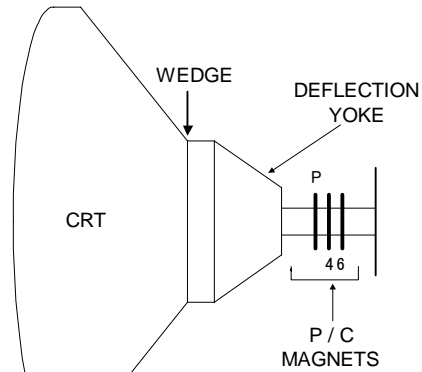

• P/C MAGNETS

P : PURITY MAGNET
4 : 4 POLES (convergence magnets)
6 : 6 POLES (convergence magnets)

Fig.1

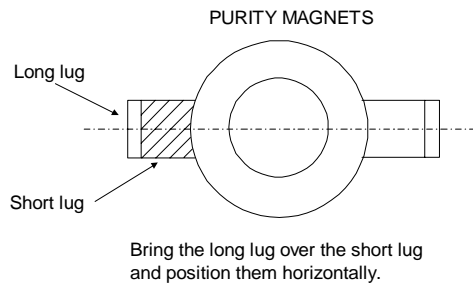

Fig.2

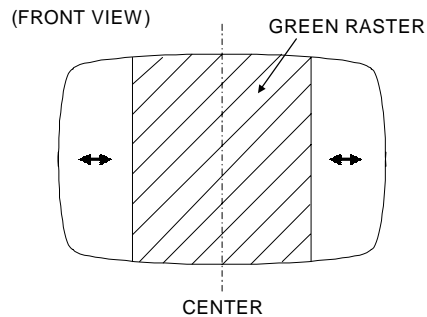

Fig.3

STATIC CONVERGENCE ADJUSTMENT

1. Input a crosshatch signal.
2. Using 4-pole convergence magnets, overlap the red and blue lines in the center of the screen (Fig.1) and turn them to magenta (red/blue).
3. Using 6-pole convergence magnets, overlap the magenta(red/blue) and green lines in the center of the screen and turn them to white.
4. Repeat 2 and 3 above, and make best convergence.

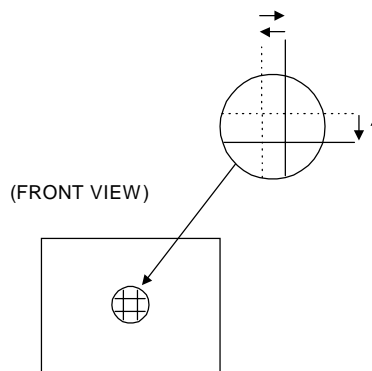

Fig.1

DYNAMIC CONVERGENCE ADJUSTMENT

1. Move the deflection yoke up and down and overlap the lines in the periphery. (Fig. 2)
2. Move the deflection yoke left to right and overlap the lines in the periphery. (Fig. 3)
3. Repeat 1 and 2 above, and make best convergence.

(FRONT VIEW)

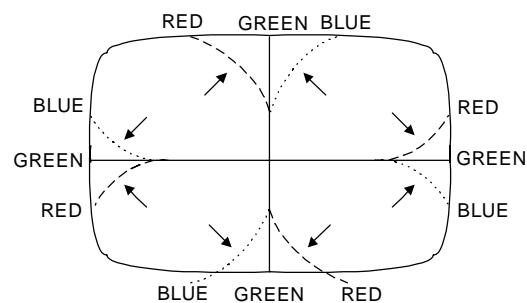

Fig.2

- After adjustment, fix the wedge at the original position.
 Fasten the retainer screw of the deflection yoke.
 Fix the 6 magnets with glue.

(FRONT VIEW)

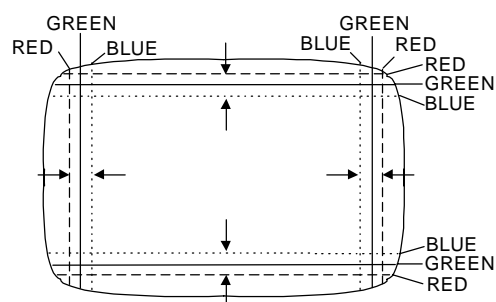

Fig.3

HOW TO CHECK THE HIGH VOLTAGE HOLD DOWN CIRCUIT

1. HIGH VOLTAGE HOLD DOWN CIRCUIT

After repairing the high voltage hold down circuit shown in Fig. 1.
This circuit shall be checked to operate correctly.

2. CHECKING OF THE HIGH VOLTAGE HOLD DOWN CIRCUIT

- (1) Turn the POWER SW ON.
- (2) As shown in Fig. 1, set the resistor (between X connector 1 & 3).
- (3) Make sure that the screen picture disappears.
- (4) Temporarily unplug the power cord.
- (5) Remove the resistor (between X connector 1 & 3).
- (6) Again plug the power cord, make sure that the normal picture is displayed on the screen.

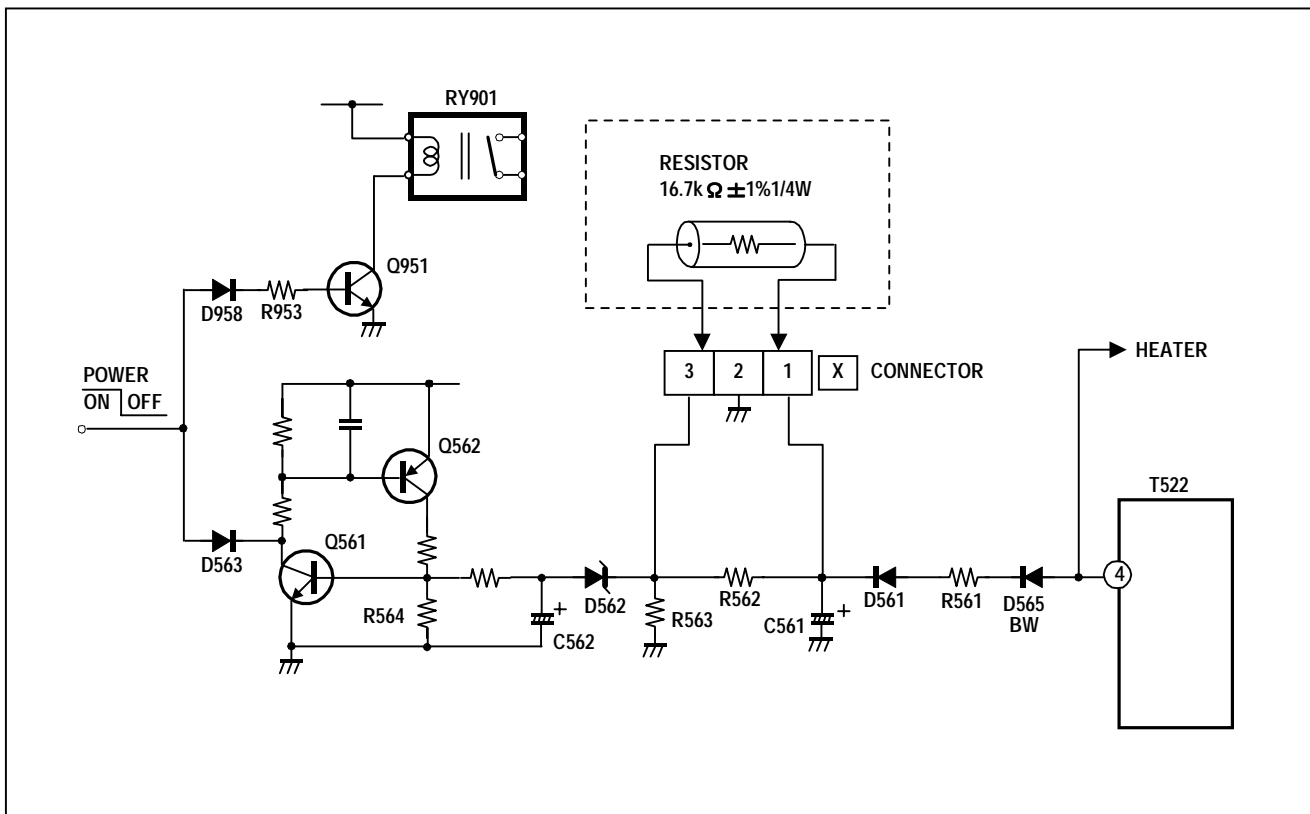

Fig. 1

SELF CHECK FUNCTIONS

1. Outline

This model has self check functions given below. When a malfunction has been detected, the POWER is turned off and the LED flashes to inform of the failure. The malfunction is detected by the signal input state of the control line connected to the microcomputer.

2. Self check items

Check item	Details of detection	Method of detection	State of malfunction
CRT NECK protector (Also detected if the power supply line output from the HVT (High voltage Transformer) has shorted with the ground.)	When the vertical circuit S-correction capacitor C427 is shorted, detect the potential drop of the C427, and prevent the burn damage to the CRT NECK. (Grounding of shorting of the power supply output from the HVT to the vertical circuit, and the small signal power supply is also detected.)	The microcomputer detects at 1 second intervals. If NG is detected for more than 1 ms, a malfunction is interpreted.	When a malfunction has been detected, the POWER is turned off. While the POWER is being turned off, the power key of the remote controller is not operational until the power code is taken out and put in again.

3. Self check indicating function

The self-check function begins detection about 5 seconds after power is supplied.

In the event a malfunction is detected, the power is cut off immediately.

At this time, the ON-TIMER LED flashes to inform of the malfunction.

[ON-TIMER LED indication]

The ON-TIMER LED flashes at 0.5 seconds intervals.

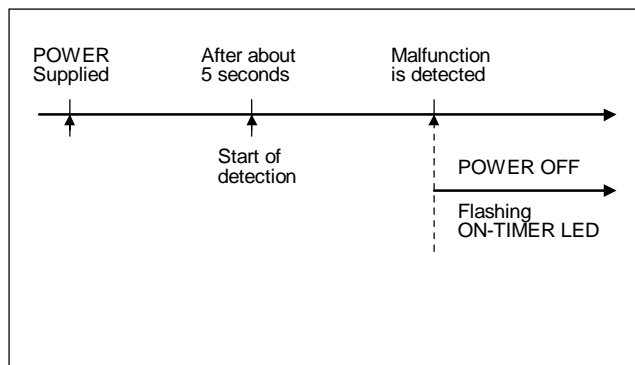

REPLACEMENT OF CHIP COMPONENT

■ CAUTIONS

1. Avoid heating for more than 3 seconds.
2. Do not rub the electrodes and the resist parts of the pattern.
3. When removing a chip part, melt the solder adequately.
4. Do not reuse a chip part after removing it.

■ SOLDERING IRON

1. Use a high insulation soldering iron with a thin pointed end of it.
2. A 30w soldering iron is recommended for easily removing parts.

■ REPLACEMENT STEPS

1. How to remove Chip parts

◆ Resistors, capacitors, etc.

- (1) As shown in the figure, push the part with tweezers and alternately melt the solder at each end.

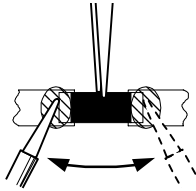

- (2) Shift with tweezers and remove the chip part.

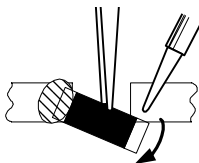

◆ Transistors, diodes, variable resistors, etc.

- (1) Apply extra solder to each lead.

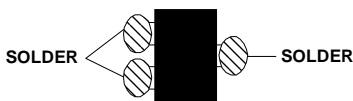

- (2) As shown in the figure, push the part with tweezers and alternately melt the solder at each lead. Shift and remove the chip part.

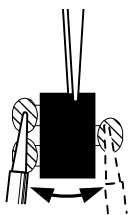

Note : After removing the part, remove remaining solder from the pattern.

2. How to install Chip parts

◆ Resistors, capacitors, etc.

- (1) Apply solder to the pattern as indicated in the figure.

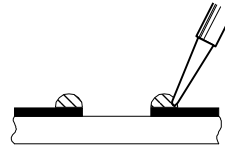

- (2) Grasp the chip part with tweezers and place it on the solder. Then heat and melt the solder at both ends of the chip part.

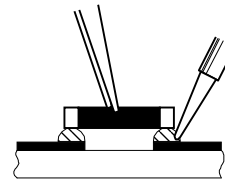

◆ Transistors, diodes, variable resistors, etc.

- (1) Apply solder to the pattern as indicated in the figure.
- (2) Grasp the chip part with tweezers and place it on the solder.
- (3) First solder lead **A** as indicated in the figure.

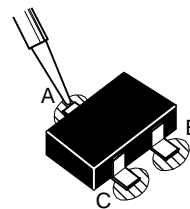

- (4) Then solder leads **B** and **C**.

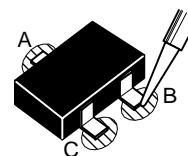

JVC

VICTOR COMPANY OF JAPAN, LIMITED

HOME AV NETWORK BUSINESS UNIT 12, 3-chome, Moriya-cho, Kanagawa-ku, Yokohama, Kanagawa-prefecture, 221-8528, Japan

N21102S-MEM #3
N21210S-MEM #3
N21202S-MEM #3



VP 0108
DP3051